

DC Servo Motors CML Series

- Small dimensions.
- Radial magnetic flux.
- High performances.
- Square format.



Encoder Specifications

Waveform	Square Wave
Line Counts	1000 ppr
Channels	A, B, Z, \bar{A} , \bar{B} , \bar{Z} / U, V, W, \bar{U} , \bar{V} , \bar{W} Line drives (RS422)
Supply Voltage	5VDC \pm 10%
Frecuency Response	200 kHz
Operating Temperature	-40 °C ~ +120 °C

Tachometer Specifications

	UNITS	TYPE
		D40
Voltage Constant	V/krpm	10 \pm 5%*
Ripple @ 1000 rpm (pp)	%	<1.5
Linearity @ 6000 rpm	%	\leq 0.1
Reversing Error	%	\leq 0.12
Temperature Coeficient	%/°C	0.03
Rotor Inertia	kg m ² 10 ⁻³	0.004
Resistance	Ω	86
Inductance	mH	13
Current	mA	2
Maximum Current	mA	8
Maximum Speed	rpm	9,000
Mass	kg	0.105

*other voltages available

Performance Curves

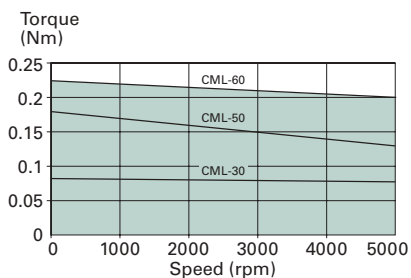

Technical Specifications

ALL CHARACTERISTICS MEASURED AT 25°C AMBIENT TEMPERATURE	SYMBOLS	UNITS	CML-30	CML-50	CML-60
RATED SPEED	n	rpm	3000	3000	3000
RATED VOLTAGE ±5%	U	V	24	24	34
RATED CURRENT	I	A	2.1	3.9	2.7
RATED OUTPUT POWER (1)	P	W	25	47	63
RATED TORQUE	T	Nm	0.08	0.15	0.2
MAX TORQUE	T _{max}	Nm	0.32	0.6	0.8
MAX SPEED WITHOUT LOAD	n _{max}	rpm	4750	5000	3550
EMF CONSTANT ±5%	K _E	V/1000 rpm	4.80	4.71	9.00
TORQUE CONSTANT ±5%	K _T	Nm/A	0.0458	0.0450	0.0859
FRICTION TORQUE	T _F	Nm	0.01	0.011	0.02
DAMPING CONSTANT	K _D	Nm/1000 rpm	0.002	0.005	0.004
TERMINAL RESISTANCE	R	Ω	3.1	1.45	2.45
ARMATURE INDUCTANCE	L	mH	1.1	0.4	0.95
ROTOR INERTIA	J	kg m ² 10 ⁻³	0.0039	0.0065	0.0094
MECHANICAL TIME CONSTANT	T _M	ms	5.75	4.66	3.12
ELECTRICAL TIME CONSTANT	T _E	ms	0.35	0.28	0.39
THERMAL TIME CONSTANT	T _{TH}	s	900	1260	1380
THERMAL RESISTANCE	R _{TH}	°C/W	3.8	2.0	1.5
MASS (Only motor. No system)	M	kg	0.38	0.50	0.62
RADIAL LOAD (at mid-length of shaft)	F _R	N	150	150	150
AXIAL LOAD	F _A	N	80	80	80
(1) With an aluminium heat sink plate			150x150x10	150x150x10	150x150x10

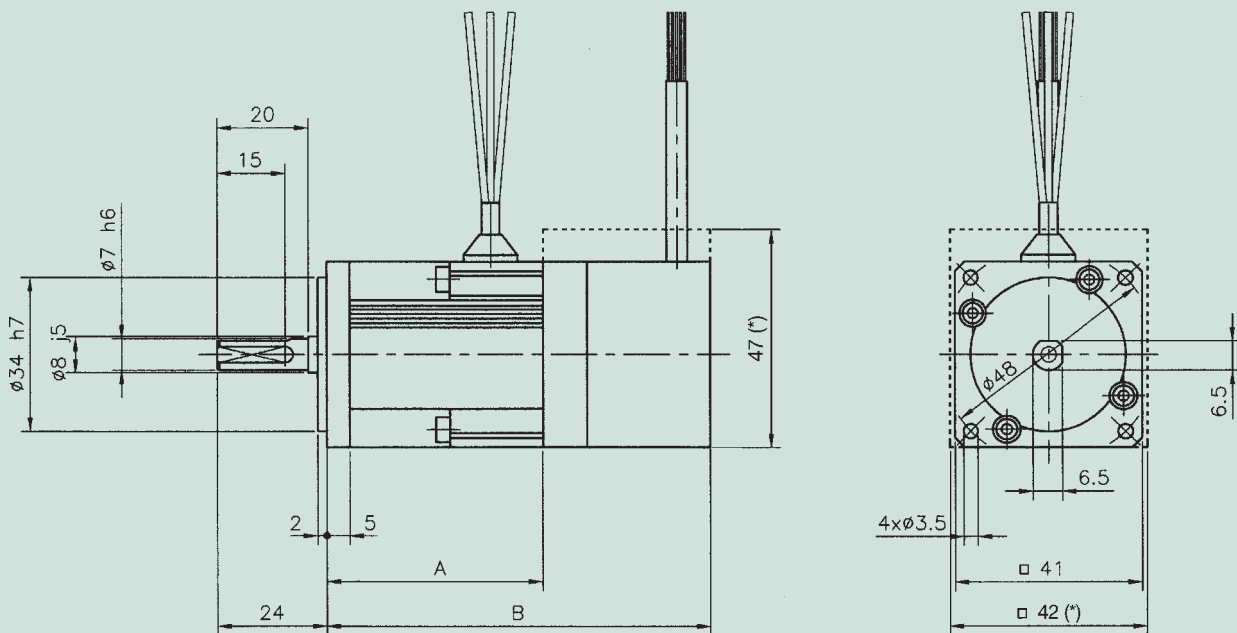

WITH ENCODER OPTION

	CML-30	CML-50	CML-60
A	47.5	62.5	77.5
B	84	99	114

WITH TACHO OPTION (*)

	CML-30	CML-50	CML-60
A	29	44	59
B	86	101	116